

Drill - Mill

MH 35G 3ph **0333-8165**

Tilting Head

MH 35V 3ph **0333-8170**

Features

- Heavy, sturdy & solid columns made of premium cast material with ground and shaven dovetail guide for excellent stability and precision
- Clockwise/Anti-clockwise rotation
- Excellent concentricity thanks to tapered roller bearings, better than 0.015mm measured in the spindle sleeve
- Gear head pivots through 60°
- Manual fine feed
- Drilling depth stop
- Thread tapping mode
- Two-stage industrial quality electric motor



MSM 3

Stand for MH35/MB4

0335-3014

65 x 55 x 75 cm

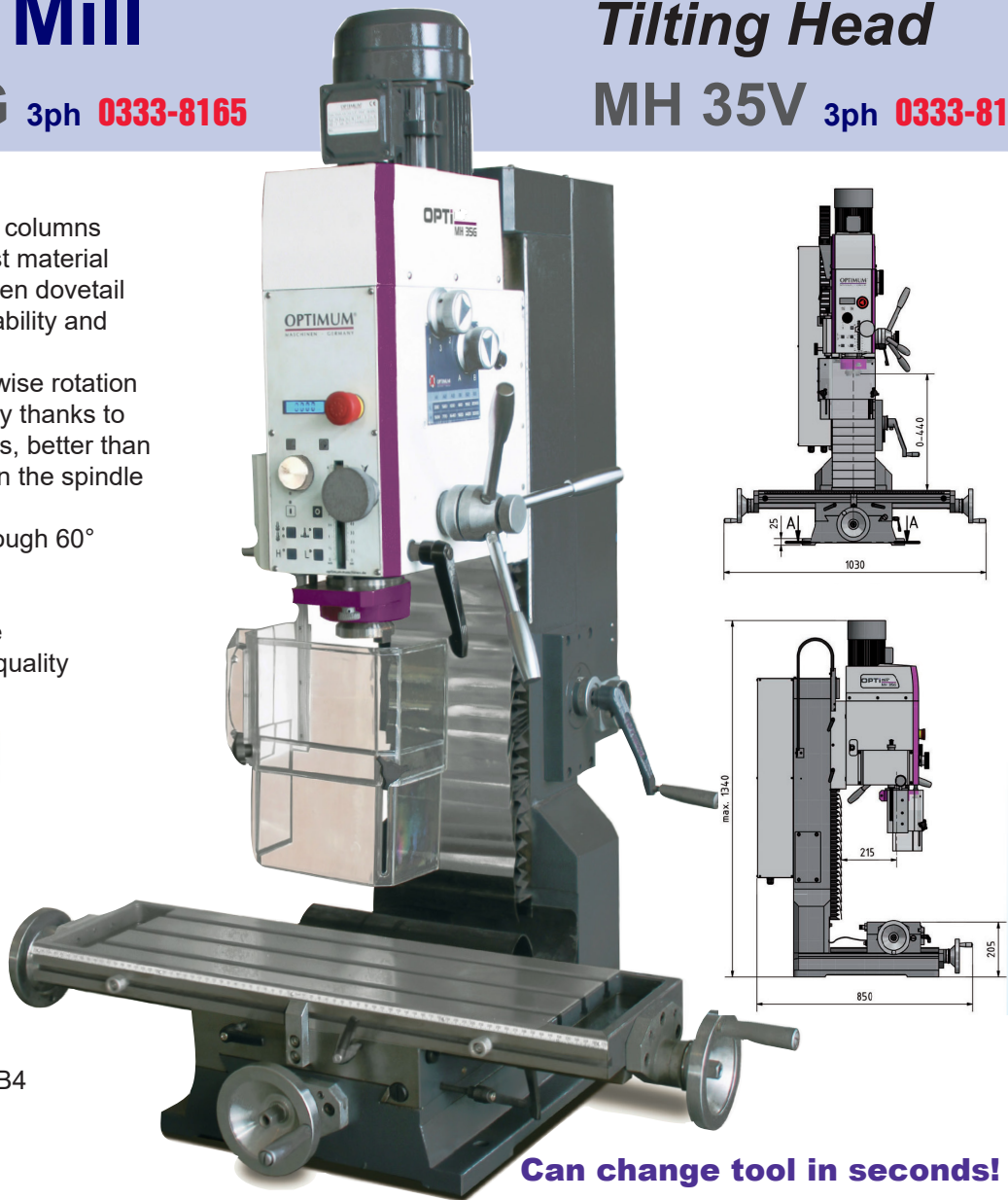

Can change tool in seconds!

Optional Accessories

BT30 x 22mm Face Mill Holder	0335-3306
BT30 Drill Chuck 1.5 - 16mm	0353-6303
BT30 x 2 MT Adapter	0335-3305
BT30 ER32 Collet Chuck	0335-3304
BT30 ER32 Collet Chuck Spanner	0335-3307
ER32 Collet Set 18 Pcs 3 - 20mm	0344-1122
Taper Cleaning Tool	0335-3301
BT30 Pull Stud	0335-3302
Uni. Table Feed V99S with E stop	0335-2021
Assembly Kit V99S X axis	0335-2035

Starter Kit BT30

0335-3282

BT30 x 22 mm Face Mill holder, BT30 1-13 mm chuck, 2 pieces each Weldon Ø 6 mm & 20 mm, 1 Weldon each Ø 8,10,12 & 16 mm, BT30 x 2 MT adaptor, BT30 ER32 collet chucks 3 Pcs, BT30 ER 32 collet chuck spanner ER32 spring collet set 18 Pcs 3-20mm, tool height adjuster, BT30 assembly & tool adjustment gauge, BT30 pull studs 14 Pcs, BT30 taper cleaning squeegee

Specification	MH 35G	MH 35V
Electrical Connection	400V. 3ph.50HZ	
Table Size LxW	750 x 210 mm	
Spindle to Table	440 mm	
T Slot	12mm / 3 / 63mm	
Travel X axis	450 mm	
Travel Y axis	200 mm	
Travel Z axis	460 mm	
Motor (2 Speed)	1.1/1.5 kW	1.5 kW
Drilling Capacity	32 mm	
Cont. Drilling Capacity	28 mm	
Spindle Taper	BT30	
Face Mill Capacity	80 mm	
End Mill Capacity	28 mm	
Quill Travel	90 mm	
Throat Depth	215 mm	
Head Swivel	± - 30%	
Gear Positions	2 x 6 steps	6 speed elec.
Spindle Speeds RPM	220 - 3,100	50-3,260
Pivot Range	± / - 60%	
Dims LxWxH(cm)	85 x 103 x 134	
Weight	316 Kg	